

T58U & T59U

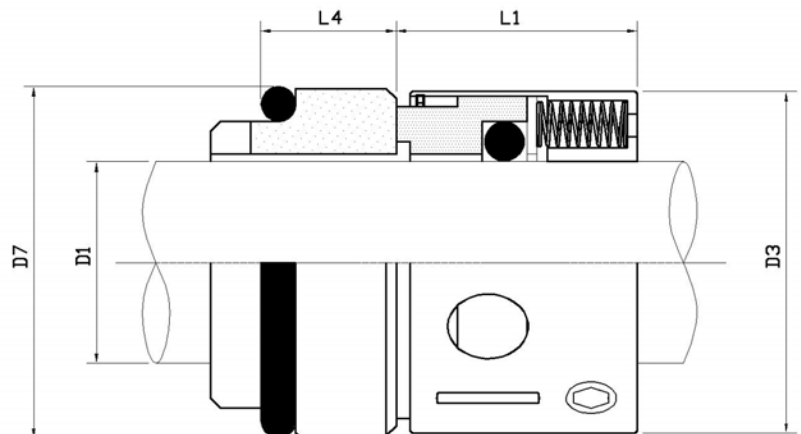

Design Features

Metric size shafts to comply with DIN 24960 L1k
Multiple spring arrangement

H58U is o-ring type seals
H59U is wedge type seals

Operating Conditions

Temperature: -30°C to +260°C
(Depending on materials used)

Pressure: Up to 17 bar , 245 psi

Speed: Up to 25m/s, 5000rpm

Materials available

Seal face: carbon/ceramic, sic/sic
Elastomer: nitrile, viton, neoprene, EPD, PTFE

Equivalent to

58U, 59U, M03S, M03

Standard seat BO, BP

Alternative seat

D1	D3	D7	L1	L4	L1K=L1+L4
22mm	36	37	24.0	13.5	37.5
24mm	38	39	26.7	13.3	40.0
25mm	39	40	27.0	13.0	40.0
28mm	42	43	30.0	12.5	42.5
30mm	44	45	30.5	12.0	42.5
32mm	46	48	30.5	12.0	42.5
33mm	47	48	30.5	12.0	42.5
35mm	49	50	30.5	12.0	42.5
38mm	54	56	32.0	13.0	45.0
40mm	56	58	32.0	13.0	45.0
43mm	59	61	32.0	13.0	45.0
45mm	61	63	32.0	13.0	45.0
48mm	64	66	32.0	13.0	45.0
50mm	66	70	34.0	13.5	47.5
53mm	69	73	34.0	13.5	47.5
55mm	71	75	34.0	13.5	47.5
58mm	78	78	39.0	13.5	52.5
60mm	80	80	39.0	13.5	52.5
63mm	83	83	39.0	13.5	52.5
65mm	85	85	39.0	13.5	52.5
68mm	88	90	39.0	13.5	52.5
70mm	90	92	45.5	14.5	60.0
75mm	95	97	45.5	14.5	60.0
80mm	104	105	45.0	15.0	60.0
85mm	109	110	45.0	15.0	60.0
90mm	114	115	50.0	15.0	65.0
95mm	119	120	50.0	15.0	65.0
100mm	124	125	50.0	15.0	65.0