

T80 & T87

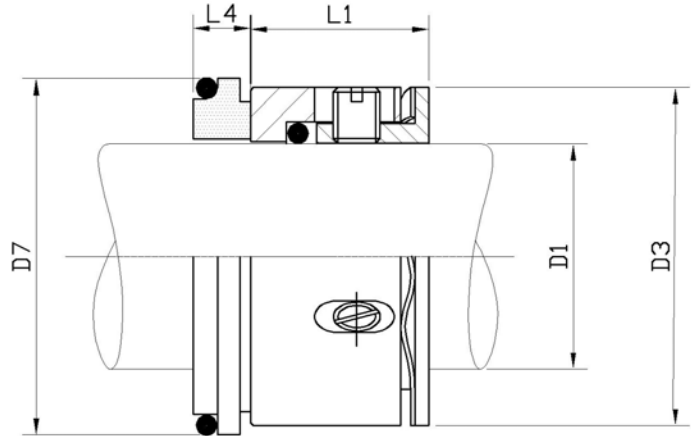

Design Features

O-ring pusher seals designed
 Wave spring arrangement
 Short working length mechanical seal
 The seal can be installed either internal or external
 Most commonly used on lobe, gear pumps

Operating Conditions

Temperature: -30°C to +200°C
 (Depending on materials used)
Pressure: Up to 10 bar , 145 psi
Speed: Up to 5.5m/s, 1100fpm

Materials available

Seal face: stainless/carbon, TC/TC
Elastomer: nitrile, viton, EPD

Equivalent to

T80,T87



D1	D3	D7	L1	L4	L=L1+L4
0.625	27.0	28.5	19.1	6.3	25.4
16mm	27.0	28.5	19.1	6.3	25.4
0.750	30.0	31.7	19.1	6.3	25.4
24mm	34.1	35.4	19.1	7.6	26.7
28mm	40.0	42.0	19.1	7.6	26.7
1.125	39.5	41.2	19.1	7.6	26.7
30mm	41.0	42.7	19.1	7.6	26.7
1.250	42.4	44.2	19.1	7.6	26.7
32mm	42.4	44.4	19.1	7.6	26.7
1.375	45.5	47.6	19.1	7.6	26.7
1.500	51.8	53.9	21.1	8.1	29.2
1.750	58.2	60.3	21.1	8.1	29.2
1.875	61.4	63.5	21.1	8.1	29.2
50mm	61.9	63.9	21.1	8.1	29.2
2.000	64.6	66.6	22.1	9.6	31.7
2.125	71.0	73.0	22.1	9.6	31.7
2.125	71.0	73.9	22.1	9.6	31.7
2.150	72.0	75.0	22.1	9.6	31.7
55mm	72.0	75.0	22.1	9.6	31.7
63mm	79.3	83.0	25.8	9.1	34.9
2.500	79.3	88.9	25.8	9.1	34.9
2.750	88.9	95.2	25.8	9.1	34.9
2.875	94.0	98.4	25.8	9.1	34.9
75mm	96.0	100.4	25.8	9.1	34.9

PUMP	D1	D3	D7	L1	L4
SR1	20mm	31.0	30	19.1	10.7
SR2	30mm	41.0	41	19.1	10.9
SR3	35mm	45.5	47	21.1	12.2
SR4	45mm	58.2	58	21.1	11.6
SR5	55mm	72.0	70	22.1	13.0
SR6	75mm	96.0	92	25.8	14.5